



# PremiumSort



on-board cleaning system

# premiumsort

easy by-pass. high capacity. simple operation. capable of straight-to-tank.

## PremiumSort Process:

1. Leaves are removed using Oxbo's three-fan cleaning system.
2. Grape clusters are destemmed and the remaining rachis is discarded evenly into the vineyard.
3. Grapes, petioles and jacks are sorted using a food safe, modular belt designed for longevity and to resist breakage even when encountering typical vineyard debris. Whole grapes and juice pass through the sorting belt while petioles, jacks, leaf fragments, and other MOG remain on the belt surface.
4. Petioles, jacks and leaf fragments are fed into an auger and then discharged from the harvester.

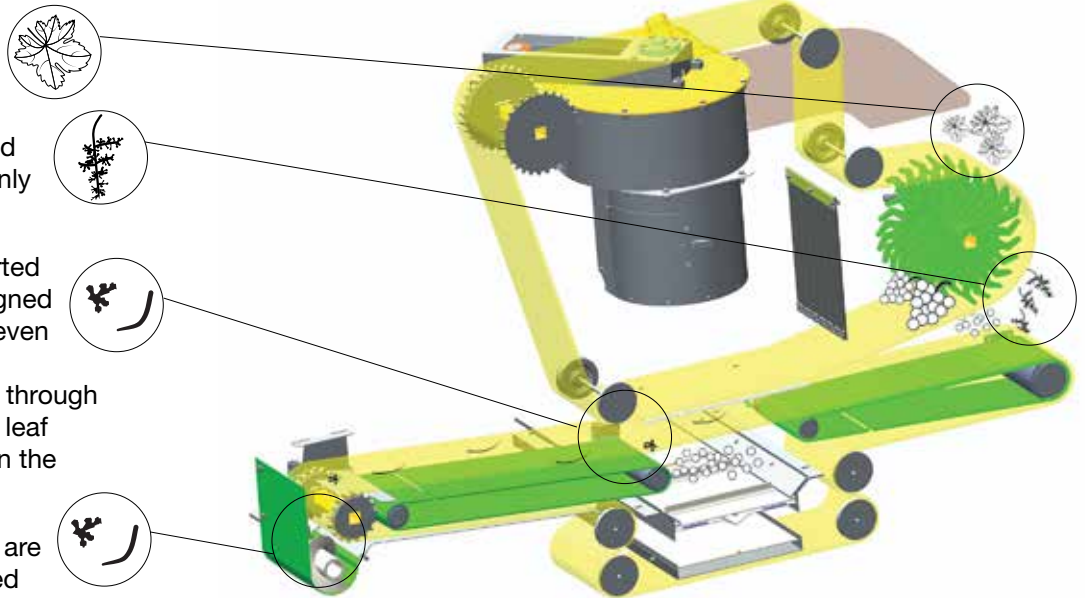

## Easy By-Pass

In a matter of seconds, the operator can by-pass the PremiumSort system and use the standard Oxbo three-fan cleaning system on the 6120, giving you ultimate harvest and cleaning flexibility.

## Straight-to-Tank Quality

PremiumSort has proven in tests across varieties and field conditions to provide you with the ability to deliver straight-to-tank quality off the Oxbo 6120. Plus, the integration with Oxbo's AVT system allows PremiumSort to deliver more clean, whole fruit.



## Easy Clean, Easy Access

Oxbo has designed swing-out doors that can be opened without tools to make cleaning and maintenance fast and easy.



## Simple Operation

Oxbo's multi-lingual control system makes it easy to operate PremiumSort. PremiumSort controls are fully integrated with the Oxbo display. Simply set the destemming difficulty and

the tonnage volume, and the system is preset for optimum cleaning. Oxbo also gives you the ability to fully customize the cleaning performance and save those settings for future use.



## Flexibility

PremiumSort was designed to be easily integrated with an over-the-row conveyor or with on-board storage options, allowing ultimate customization.



## High Capacity

In documented field tests, PremiumSort has proven to handle higher tonnages, at higher ground speeds in a variety of extreme slope conditions.

## Quality Materials, Easy Maintenance

The modular, food safe destemmer belt provides long, reliable field performance and impact resistance. The durometer of the destemmer fingers and pattern leave an unobstructed path for removing the rachis while preserving fruit integrity.



## Patent-Pending Sorting

The perforations of the sorting belt coupled with a ratchet motion enables the PremiumSort system to work with a wide range of grape varieties.

